



HiPace[®] 80 with TC 110, DN 63 ISO-K



Similar Image

HiPace® 80 with TC 110, DN 63 ISO-K

- Small yet powerful turbopump with a pumping speed of up to 67 l/s for N₂
- Integrated TC 110 drive electronics
- For installation in any orientation
- Ideal for dependable systems integration
- Extensive accessories expand the range of applications

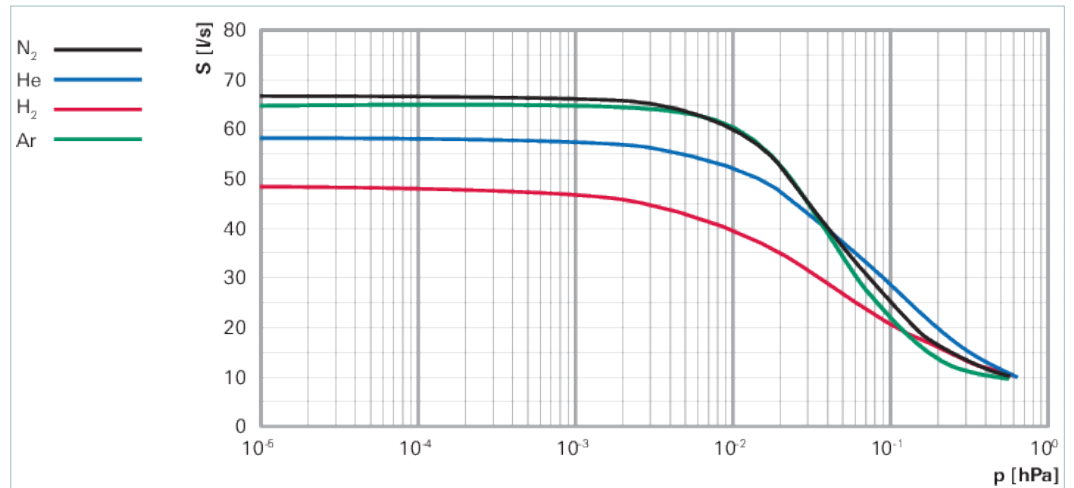

Dimensions

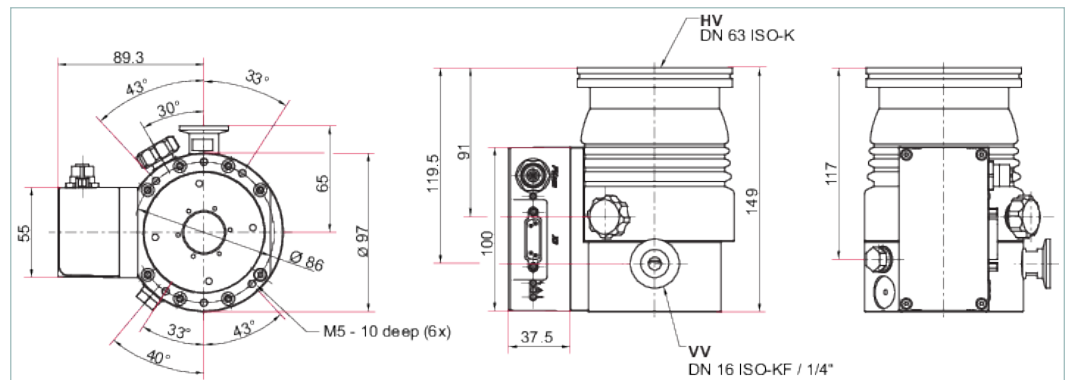

Technical Data	HiPace® 80 with TC 110, DN 63 ISO-K
Bearing	Hybrid
Compression ratio for Ar	$> 1 \cdot 10^{11}$
Compression ratio for H ₂	$1.4 \cdot 10^5$
Compression ratio for He	$1.3 \cdot 10^7$
Compression ratio for N ₂	$> 1 \cdot 10^{11}$
Connection flange (in)	DN 63 ISO-K
Connection flange (out)	DN 16 ISO-KF/G 1/4"
Cooling method	Convection
Cooling method, optional	Air Water
Cooling water flow	75 l/h
Cooling water flow, max.	75 l/h
Cooling water flow, min.	75 l/h
Cooling water temperature	5-25 °C 41-77 °F 278-298 K
Current, max.	4,6 A
Electronic drive unit	TC 110

Technical Data	HiPace® 80 with TC 110, DN 63 ISO-K
Final pressure	$< 1 \cdot 10^{-7}$ hPa $< 7.5 \cdot 10^{-8}$ Torr $< 1 \cdot 10^{-7}$ mbar
Fore-vacuum max. for N ₂	22 hPa 16.5 Torr 22 mbar
Gas throughput at final rotation speed for Ar	0.54 hPa-l/s
Gas throughput at final rotation speed for H ₂	15.3 hPa-l/s
Gas throughput at final rotation speed for He	2.7 hPa-l/s
Gas throughput at final rotation speed for N ₂	1.3 hPa-l/s
I/O interfaces	RS-485, Remote
Input voltage(s)	24 V DC (±10 %)
Integral leak rate	$< 1 \cdot 10^{-8}$ Pa m ³ /s $< 7.5 \cdot 10^{-8}$ Torr l/s $< 1 \cdot 10^{-7}$ mbar l/s
Mains frequency compatibility	50 Hz 60 Hz
Mounting orientation	Arbitrary
Permissible radial magnetic field max.	3.8 mT
Position of power supply pack	External power supply pack
Power consumption max.	110 W
Protection degree	IP44 Type 12
Pumping speed for Ar	66 l/s
Pumping speed for H ₂	48 l/s
Pumping speed for He	58 l/s
Pumping speed for N ₂	67 l/s
Rotation speed ± 2 %	90,000 rpm 90,000 min ⁻¹
Rotation speed variable	50 – 100 %
Run-up time	1.7 min
Sound pressure level	≤48 dB(A)
Type of electronic drive unit installation	Integrated electronic drive unit
Venting connection	G 1/8"
Weight	2.4 kg 5.29 lb

Order number	
HiPace® 80	PM P03 940

Accessories	
Adapters (electrical) Remote	
Housing for plug, spraywater-protected, 15-pole, D-Sub	P 0998 016
D-Sub mains power plug, 15-pin, straight outgoing cable	P 4723 110
D-Sub mains power plug, 15-pin, angled outgoing cable	P 4723 111
TCS 11, adapter for TC 110/120 with RS-485 interface	PM 061 636 -U
TCS 12, adapter for TC 110/120 with interface RS-485, 4 accessory ports and coupling set	PM 061 638 -U
TCS 13, adapter for TC 110/120 with interface RS-485, 2 accessory ports and coupling set	PM 061 856 -U
TCS 17 for control of backing pumps	PM 071 093 -U
Adapters (electrical) RS-232/485	
Y-connector M12 for RS-485	P 4723 010
USB RS-485 converter	PM 061 207 -T
Coupling M12 for RS-485	PM 061 270 -X
Terminal resistor for RS-485	PT 348 105 -T
Power separator for RS-485	PT 348 132 -T
Cables Backing pump control cables	
HiPace – ACP connection cable	PM 071 142 -X
Connection cable MVP-TC-TPS, 3 m	PE 100 013 -T
Cables Connection cables	
Connecting cable from 24V/48V power supply pack to electronic drive unit. With RS-485 interface	PM 061 350 -T
Connection cable with RS-485 interface and 2 accessory ports for TC110/120 to power supply pack	PM 061 351 -T
Connection cable TPS 180 - MVP 006-4 with HiPace 80/HiPace 10, 2 x 0.5 m	PM 061 399 -T
Connection cable with RS-485 interface and 3 accessory ports for TC110/120 to power supply pack	PM 061 512 -T
Connection cable for HiPace with TC 110/120	PM 061 543 -T
Connection cable incl. 2 accessory ports for TC 110/120 to power supply pack	PM 061 552 -T
Cables Extension cables	
Extension cable M8 on M8	PM 061 783 -T
Cables Mains cables / Power cords	
Mains cable 230 V AC, CEE 7/7 to C13, 3 m	P 4564 309 ZA
Mains cable 115 V AC, NEMA 5-15 to C13, 3 m	P 4564 309 ZE
Mains cable 208 V AC, NEMA 6-15 to C13, 3 m	P 4564 309 ZF
Cables RS-485 Interface cables	
Interface cable, M12 m straight / M12 m straight, 3 m	PM 061 283 -T
Interface cable, M12 m straight / M12 m angled, 0.7 m	PM 061 791 -T
Connections Connection kits for mounting of pumps	
Connection kit for mounting of pumps, DN 16 ISO-KF	120SWS016-1000
Control Devices Backing pump	
Relay box for backing pumps, 1-phase motor 20 A for TC 110/120 and TCP 350, plug M8	PM 061 373 -T
Relay box, shielded, for backing pumps, 1-phase motor 7A for TC 110/120 and TCP 350, plug M8	PM 071 282 -X

Accessories	
Control Devices Power supplies and control displays	
TPS 110, power supply pack for wall/standard rail installation	PM 061 340 -T
TPS 180, power supply pack for wall/standard rail installation	PM 061 341 -T
TPS 111, power supply pack 19" plug-in unit 3HU	PM 061 344 -T
TPS 181, power supply pack 19" plug-in unit 3HU	PM 061 345 -T
Front panel kit for TPS 111	PM 061 393 -T
Front panel kit for TPS 181	PM 061 394 -T
OmniControl 200, rack unit with integrated power supply pack	PE D52 000 0
OmniControl 200, table unit with integrated power supply pack	PE E52 110 0
OmniControl 001, rack unit without integrated power supply pack	PE D42 100 0
OmniControl 001 Mobile, control units	PE D22 000 0
Cooling Air cooling	
Air cooling for HiPace 60 P, HiPace 80 and SplitFlow 50/80 with TC 110/120	PM Z01 300
Air cooling for HiPace 60/80, SplitFlow 50/80, 230 V	PM Z01 343
Air cooling for HiPace 60 P and 80, SplitFlow 50/80, 115 V	PM Z01 344
Air cooling, shielded	PM Z01 369
Cooling Water cooling	
Water cooling for HiPace 60 P / 80 / 350 / 450 and for SplitFlow 50 / 80 with push-in fitting, 8 mm	PM 016 623 -T
Water cooling for HiPace 30 HiPace 80 mini with push-in fitting, 8 mm	PM 016 847 -T
Monitoring Pressure Sensors	
OmniControl 200, table unit with integrated power supply pack	PE E52 100 0
OmniControl 200 mit PKR 361, 40 CF	PT 440 957 -T
Mounting DN ISO-K, Mounting kits, bracket screws	
Mounting kit for HiPace 60/80, DN 63 ISO-K, including coated centering ring and bracket screws	PM 016 360 -T
Mounting kit for HiPace 60/80, DN 63 ISO-K, including coated centering ring, splinter shield and bracket screws	PM 016 361 -T
Mounting kit for HiPace 60/80, DN 63 ISO-K, including coated centering ring, integrated protective screen, bracket screws	PM 016 362 -T
Mounting DN ISO-K, Mounting kits, claws	
Mounting kit for HiPace 60/80, DN 63 ISO-K, including coated centering ring and claws	PM 016 510 -T
Mounting kit for HiPace 60/80, DN 63 ISO-K, including coated centering ring, splinter and claw grips	PM 016 511 -T
Mounting kit for HiPace 60/80, DN 63 ISO-K, including coated centering ring with integrated protection screen and claw grips	PM 016 512 -T
Mounting DN ISO-K/F, sealings	
Centering ring with multifunction coating, DN 63 ISO-K/F	PM 016 206 -U

Accessories	
Mounting DN ISO-K/F Mounting kits	
Mounting kit for DN 63 ISO-K to ISO-F, with collar flange, coated centering ring, hexagon bolts	PM 016 930 -T
Mounting kit for DN 63 ISO-K to ISO-F, with collar flange, coated centering ring with splinter shield, hexagon bolts	PM 016 931-T
Mounting kit for DN 63 ISO-K to ISO-F, with collar flange, coated centering ring with protection screen, hexagon bolts	PM 016 932 -T
Mounting kit for DN 63 ISO-K to ISO-F, with collar flange, coated centering ring, stud screws	PM 016 935 -T
Mounting kit for DN 63 ISO-K to ISO-F, with collar flange, coated centering ring with splinter shield, stud screws	PM 016 936 -T
Mounting kit for DN 63 ISO-K to ISO-F, with collar flange, coated centering ring with protection screen, stud screws	PM 016 937 -T
Protection DN ISO-K/F, sealings, splinter shields, protection screens	
Centering ring with multifunction coating and integrated splinter shield, DN 63 ISO-K/F	PM 016 207 AU
Centering ring with multifunction coating and integrated protection screen, DN 63 ISO-K/F	PM 016 208 AU
Protection Sealing gas throttles	
Sealing gas throttle for HiPace 30/60/80	PM Z01 316
Valves Fore-vacuum safety valves	
TVV 001, fore-vacuum safety valve, 230 V AC	PM Z01 205
TVV 001, fore-vacuum safety valve, 115 V AC	PM Z01 206
Valves Isolation valves	
HV gate valve, DN 63 ISO-F, electro-pneumatic, PI (RS)/PV 24 V DC, SS/FKM	GVP-S06342
Valves Sealing gas valves, shielded (normally closed)	
Sealing gas valve, shielded for HiPace 30/60/80 with TC 110	PM Z01 310
Venting Power failure venting units (normally open)	
Shielded power failure venting unit, 24 V DC, G 1/8", for connection to TC 110/120	PM Z01 330
Venting Venting accessories	
Flange with pipe thread, DN 16 ISO-KF, G 1/8"	PM 016 780 -T
Push-in fitting for 6 mm tube, G 1/8"	PM 016 781 -T
Push-in fitting for 8 mm tube, G 1/8"	PM 016 782 -T
Hose nozzle for 9 mm hose, G 1/8"	PM 016 783 -T
Banjo fitting	PM 016 787 -T
Screw-in flange, DN 10 ISO-KF, G 1/8"	PM 033 737 -T
Banjo fitting, small	PM 143 877 -T
Venting Venting valves (normally closed)	
Venting valve, shielded, 24 V DC, G 1/8", for connection to TC 110/120	PM Z01 290
Venting valve, 24 V DC, G 1/8" without cable	PM Z01 293
Vibration Reduction Vibration dampers	
Vibration damper for HiPace 60/80, DN 63 ISO-K	PM 006 800 -X

VACUUM SOLUTIONS FROM A SINGLE SOURCE

Pfeiffer Vacuum stands for innovative and custom vacuum solutions worldwide, technological perfection, competent advice and reliable service.

COMPLETE RANGE OF PRODUCTS

From a single component to complex systems:

We are the only supplier of vacuum technology that provides a complete product portfolio.

COMPETENCE IN THEORY AND PRACTICE

Benefit from our know-how and our portfolio of training opportunities!

We support you with your plant layout and provide first-class on-site service worldwide.

Are you looking for a
perfect vacuum solution?
Please contact us:

Pfeiffer Vacuum GmbH
Headquarters · Germany
T +49 6441 802-0
info@pfeiffer-vacuum.de

www.pfeiffer-vacuum.com

All data subject to change without prior notice.

PFEIFFER  **VACUUM**